

# CBE2000 Pro

## Energy Storage System

### User Manual



# About This Document

## Overview

This document applies to the following product models:

**CME03-2BS204** (CME03-2BS204-1, CME03-2BS204-2, CME03-2BS204-3, CME03-2BS204-4, CME03-2BS204-5, CME03-2BS204-1A, CME03-2BS204-2A)

**CME03-2BS204-08** (CME03-2BS20408-1, CME03-2BS204-08-2, CME032BS204-08-3, CME03-2BS204-08-4, CME03-2BS204-08-5, CME03-2BS204-08-1A, CME03-2BS204-08-2A)

**CME03-2BS204-19** (CME03-2BS20419-1, CME03-2BS204-19-2, CME032BS204-19-3, CME03-2BS204-19-4, CME03-2BS204-19-5, CME03-2BS204-19-1A, CME03-2BS204-19-2A)

**CME03-2BS204-07** (CME03-2BS20407-1, CME03-2BS204-07-2, CME032BS204-07-3, CME03-2BS204-07-4, CME03-2BS204-07-5, CME03-2BS204-07-1A, CME03-2BS204-07-2A)

This document primarily introduces CBE2000 Pro the balcony energy storage system (hereinafter referred to as "product", "device", or "energy storage") including product overview, applications, installation and debugging, maintenance, and technical data.

## Target Audience





Intended Audience This document is intended for:

- Sales engineers
- Solution design engineers
- Service engineers
- End users









## Safety Symbol Specification

The following symbols may appear in this article, and their meanings are as follows:

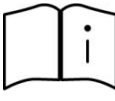
Attention Symbol	Description
 DANGER	A high hazard level indicates that non-compliance or not taking preventative measures could result in death or serious

	injuries.
 WARNING	Medium hazard level signifies that non-compliance or not taking preventative measures could lead to death or serious injuries.
 CAUTION	A low hazard level represents the possibility of minor injuries if not compliant or preventive measures are not taken.
 NOTICE	The presence of potential risks signifies that non-compliance or not taking precautions could lead to equipment damage or other unpredictable impacts.
 NOTE	This expresses additional key information and does not involve alerts about equipment or personal safety.

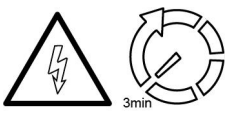
## Symbol Description

Symbol	Description
	Electrical hazard, do not touch.
	Pay attention to safety.
	High temperature hazard, do not touch.
	Read the user manual and all safety instructions carefully before installation, operation, and maintenance.
	Do not dispose of the device as household waste. Follow local electronic waste disposal regulations.
	The product is recyclable
	The device complies with the essential requirements of the relevant EU legislation.
	Wait at least 3 minutes after all voltage sources are disconnected before servicing.
	Indicates the position for connecting the protective earthing (PE) cable.

## Change Record

Change history accumulates the description of each document update. The latest issue of the document contains all changes made in previous issues.

**Issue: 02 (2026-01-05)**

APP Interface and function changes, Version: 1.5.4.

Add information related to expansion battery 5000.

**Issue: 01 (2025-11-27)**

This issue is the first official release.

---

# Contents

---

<b>1 Safety Use Instructions .....</b>	<b>1</b>
<b>2 Product Introduction .....</b>	<b>6</b>
2.1 System Introduction .....	6
2.2 Interface Introduction .....	7
2.3 Technical Specifications .....	10
<b>3 Product Installation .....</b>	<b>14</b>
3.1 Unboxing and Inspection .....	14
3.2 Prepare Tools .....	15
3.3 Installation Environment Requirements .....	15
3.4 Install Equipment .....	15
3.4.1 Installation (Main battery) .....	15
3.4.2 Installation (Main battery and expansion battery) .....	16
<b>4 Product Wiring .....</b>	<b>18</b>
4.1 PV Panels Wiring .....	19
4.2 Install the Cables (New Installation) .....	20
4.3 Install the Cables (Existing PV System Retrofit) .....	21
<b>5 Product Network Configuration .....</b>	<b>23</b>
5.1 Download the CONOW ECO App .....	23
5.2 Log in / Sign up .....	23
5.3 Device Network Configuration .....	25
5.4 (Optional) Added Other Devices .....	26
5.5 Introduction to Function Settings .....	27
<b>6 Product Maintenance .....</b>	<b>33</b>
6.1 Alarm Handling .....	33
6.2 Warranty Exclusions .....	35
6.3 Routine Maintenance .....	35
<b>7 Emergency Handling .....</b>	<b>37</b>

# 1 Safety Use Instructions

---

## Statement

Before using the device, you must read this manual, operate strictly according to the contents of the manual, and follow all safety precautions indicated on the device and within the manual.

Safety precautions in the manual serve as supplementary or highlight explanations. You also need to abide by relevant international, national, or regional standards and industry practices. Our company does not assume any liability resulting from violations of safety operation requirements, or contraventions to design, production, and device safety standards.

This device should be used in environments that meet the design specification requirements. Otherwise, any device failures, abnormal device functions, or part damages that may occur will not be covered by the device's warranty. Furthermore, we will not be held accountable for any personal injuries or property losses that could occur.

## General Requirements

- Installation, operation, and maintenance must be performed according to the sequence in the manual. Do not modify, add to, or change the equipment arbitrarily, nor should you change the installation sequence on your own.
- It is strictly forbidden to manually alter, damage, or cover the marks and nameplates on the equipment. Replace any markings that have become faded from long-term use.
- Please use batteries within the prescribed temperature range. A charge is prohibited when the environmental temperature is below the lower limit of the operating temperature to avoid internal short circuits caused by low-temperature charge.
- Before unpacking the battery, check to ensure that the packaging is intact. Batteries with damaged packaging must not be used. If damaged, immediately inform the transporter and the manufacturer.
- Battery damage (falls, collisions, swelling or dents in the casing, etc.) may lead to the release of leakage or flammable gases. Do not use a damaged battery. When the battery shows signs of leakage or structural deformation, immediately contact the installer or a professional for removal and replacement. Do not store damaged batteries near other devices or combustible materials, and non-professionals should not approach the damaged battery.
- If the battery unintentionally gets wet, do not continue the installation and promptly move it to a safe isolation point for scrapping.

- If the battery will not be used for a long time, it should be stored and charged according to the battery requirements.
- It is prohibited to use equipment that does not comply with local laws, regulations, and standards for charge and discharge.
- When the battery fails, the surface temperature may become too high. Avoid touching it to prevent burns.
- Do not stand or lean, sit on the equipment.
- Do not use the battery for the following purposes.
  - For medical devices directly related to human life.
  - For control equipment such as trains, elevators, etc., which may cause personal injury.
  - For computer systems of social and public importance.
  - At locations near medical devices.
  - For any equipment within the descriptions above.

## Grounding

- The equipment's grounding impedance should meet local electrical standards.
- The equipment should be permanently connected to protective ground. Before operating the device, check the electrical connections of the equipment to ensure reliable grounding.

## Battery Safety

- Never short-circuit the positive and negative terminals of the battery, as this can cause a short circuit. A battery short circuit can generate a large current and release a large amount of energy instantly, leading to battery leaks, smoke, the emission of flammable gases, thermal runaway, fire, or explosion.
- Do not expose batteries to high-temperature environments or heat-emitting equipment, such as intense sunlight, fire sources, transformers, heaters, etc. Overheating a battery may lead to leaks, smoke, the emission of flammable gases, thermal runaway, fire, or explosion.
- It is strictly forbidden for batteries to be subjected to mechanical vibrations, falls, collisions, hard object punctures, and pressure impacts. Otherwise, it may cause battery damage or fires.
- Dismantling, modifying, or damaging the battery (such as inserting foreign objects, crushing with external forces, or immersing in water or other liquids) is strictly prohibited, to avoid leaks, smoke, the emission of flammable gases, thermal runaway, fire, or explosion.
- Battery terminals should not come into contact with other metal objects, which could lead to heating or electrolyte leakage.
- Battery electrolyte is toxic and volatile. In the event of electrolyte leakage or abnormal smell, avoid contact with the leaking liquid or gas. Non-professionals should keep their distance and immediately contact professionals. Professionals should be equipped with safety goggles, rubber gloves, gas masks, protective suits, etc., disconnect the equipment promptly, remove the leaking battery, and contact the technical engineers.
- A battery is a sealed system and will not release any gases under normal operation.

- However, under extremely misused circumstances such as fire, stabbing, squeezing, lightning strike, overcharge, or other situations that could potentially lead to thermal runaway, battery damage or abnormal chemical reactions within the battery could occur, resulting in electrolyte leakage or the generation of gases such as CO, H<sub>2</sub>. Ensure that flammable gas emissions are properly managed at the site to avoid causing combustion or corroding equipment.

## Recycling and Disposal

- Please handle waste batteries according to local laws and regulations. Do not treat batteries as domestic waste. Improper battery disposal may result in environmental pollution or explosions.
- If the battery leaks or is damaged, please contact technical support or a battery recycling company for disposal.
- When the battery is out of life and unusable, please contact a battery recycling company for scrapping.
- Avoid exposing waste batteries to high temperatures or direct sunlight.
- Avoid exposing waste batteries to high humidity or corrosive environments.
- Faulty batteries are prohibited from being used for a second time. Contact a battery recycling company for disposal as soon as possible to prevent environmental pollution.

## Storage

- Batteries should be stored indoors, where they are not exposed to direct sunlight or rain, in a well-ventilated and dry environment. The surrounding area should be kept clean and free from significant radiation, such as infrared rays, organic solvents or corrosive gases, and conductive metallic dust, and the storage should be far from heat sources and flames.
- Suppose a battery fault occurs (carbonization, leakage, expansion, water ingress, etc.). In that case, it must be promptly moved to a hazardous materials warehouse for isolated storage, at a distance of no less than 3 meters from any surrounding combustible materials, and be disposed of as quickly as possible.
- When storing batteries, they should be placed correctly according to the indications on the packaging box. It is strictly forbidden to place them upside down, sideways, or at an angle. When stacking, the arrangement should adhere to the requirements mentioned on the outer packaging.
- When storing batteries, please store them separately to avoid mixing with other equipment and prevent batteries from being stacked too high. When a large number of batteries are being stored on-site, it is recommended to have appropriate fire-fighting equipment on hand, such as fire sand and fire extinguishers.
- It is recommended to use the battery promptly. For batteries that are stored for a long time, please carry out regular recharge, otherwise, it may cause battery damage.
- The storage environment must meet local legal regulations and standard requirements.
- The environmental air should not contain corrosive or flammable gases.
- Storage environment requirements:

- Ambient Temperature: -20°C to +55°C, recommended storage temperature: 20°C-30°C.
- Relative Humidity: 10%RH-85%RH.
- When exceeding the storage period, it is required to undergo inspection and testing by professionals before use.
- During storage, it is necessary to keep relevant evidences that meet the product storage requirements, such as temperature and humidity log data, storage environment photos, and inspection reports.
- When shipping batteries, follow the principle of first in, first out.
- Storage time should be calculated from the most recent charge time indicated on the battery's external packaging. After the charge, update the most recent charge time.

## Transportation

- Prohibit rough handling during installation or removal as it may result in battery short circuit, damage (such as leakage or rupture), fire, or even explosion.
- During transport, the battery should be moved following its specified orientation. Arbitrary handling of the battery is prohibited.
- Before unpacking the battery, during storage and transportation, ensure the outer packaging box is intact and undamaged. Arrange it as indicated by the marks on the box, sternly disallowing inverting, putting it on its side, standing it up, or tilting. When stacking, follow the order given on the packaging to prevent any collisions or falls that could damage and ruin the battery.
- Batteries have obtained the certifications of the UN38.3 (UN38.3: section 38.3 of the sixth Revised Edition of the Recommendations on the Transport of Dangerous Goods, Manual of Tests and Criteria) and SN/T 0370.2-2009 (Part 2: Performance Test of the Rules for the Inspection of Packaging for Exporting Dangerous Goods). This product belongs to class 9 dangerous goods.
- The transport service provider should be qualified to transport the corresponding equipment.
- Comply with the international transport rules for dangerous goods and meet the regulatory requirements of the transport regulatory authorities of the country of origin, route, and destination of the transport.
- Maritime transport must comply with the *International Maritime Dangerous Goods Code* (IMDG Code).
- Road transport must comply with the *Agreement Concerning the International Carriage of Dangerous Goods by Road* (ADR) or JT/T 617.
- Before transportation, it is essential to verify that the battery packaging is complete and undamaged and that there are no unusual smells, liquid leakage, smoke, or fire. If any of these conditions are present, transportation is prohibited.
- The box used for transportation must be sturdy. During loading, unloading, and transport, it should be handled gently and kept moisture-proof.
- When moving the battery, careful attention should be taken not to knock or drop it.
- Unless otherwise provided, hazardous materials cannot be mixed in the same vehicle or container with goods containing food, medicines, animal feed, or their

additives.

- Unless otherwise specified, when hazardous goods are loaded with ordinary goods in the same vehicle or container, one of the following isolation methods should be adopted:
  - Using a barrier that is the same height as the package
  - Keeping a separation of at least 0.8m on all sides
- Before moving a faulty battery (carbonized, leaking, swollen, water ingress, etc.), the positive and negative terminals should be insulated. After packing, it should be rapidly placed in an insulated explosion-proof box, and a record should be kept on the outer box, including details such as the name of the site, address, time, and observed issues.
- Faulty batteries should be moved away from the site during transportation and avoid areas where flammable materials are stored, residential areas, or other places where people often gather, such as public transport vehicles or elevators.

# 2 Product Introduction

## 2.1 System Introduction

### Overview

The CBE2000 Pro combines stackable and all-in-one design allows for easy integration into various spaces, adapting to your specific energy needs. It supports dynamic electricity pricing and real-time power management, while its AC-input charging enables reliable grid-based backup or peak-shaving operation. It's powered by AI-driven insights that optimize charging schedules, predict maintenance needs, and enable imbalance-market trading.

### System Network

Figure 2-1 Network diagram (New installation)

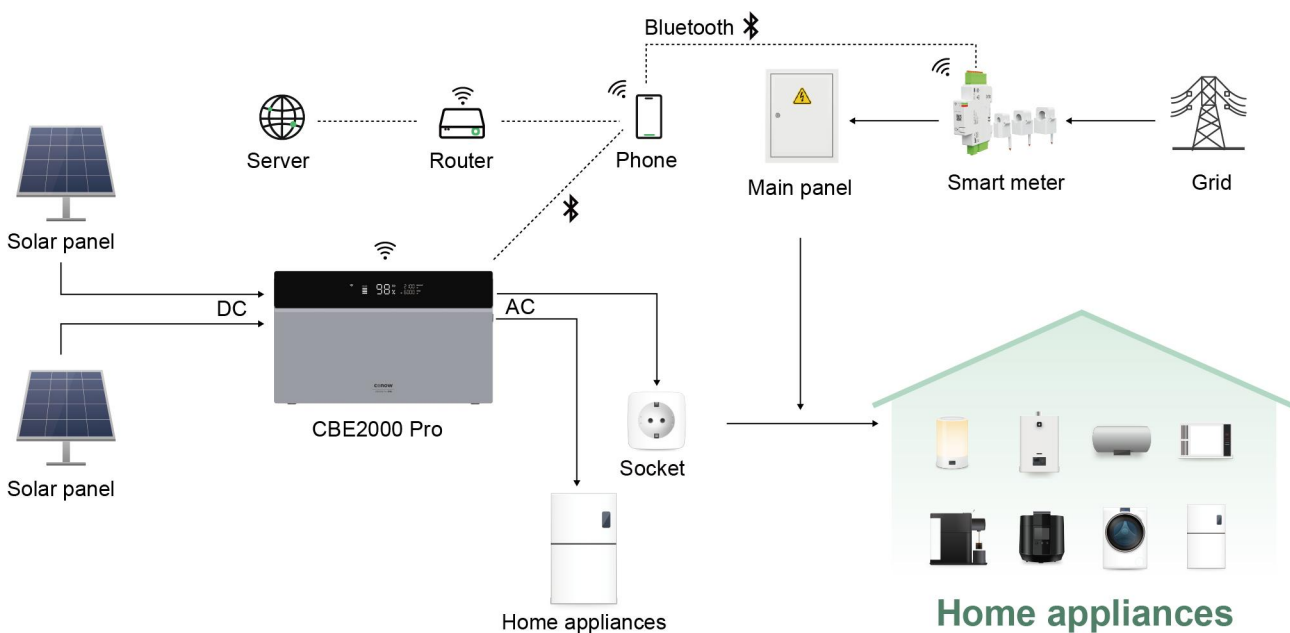

#### ⚠ NOTICE

- The system supports the parallel operation of two hosts with identical wiring configurations. Please configure according to your actual requirements.
- The system can also operate as a pure AC-coupled configuration. When used in pure AC-coupled mode, there is no need to deploy solar photovoltaic panels.

Figure 2-2 Network diagram (Existing PV system retrofit)

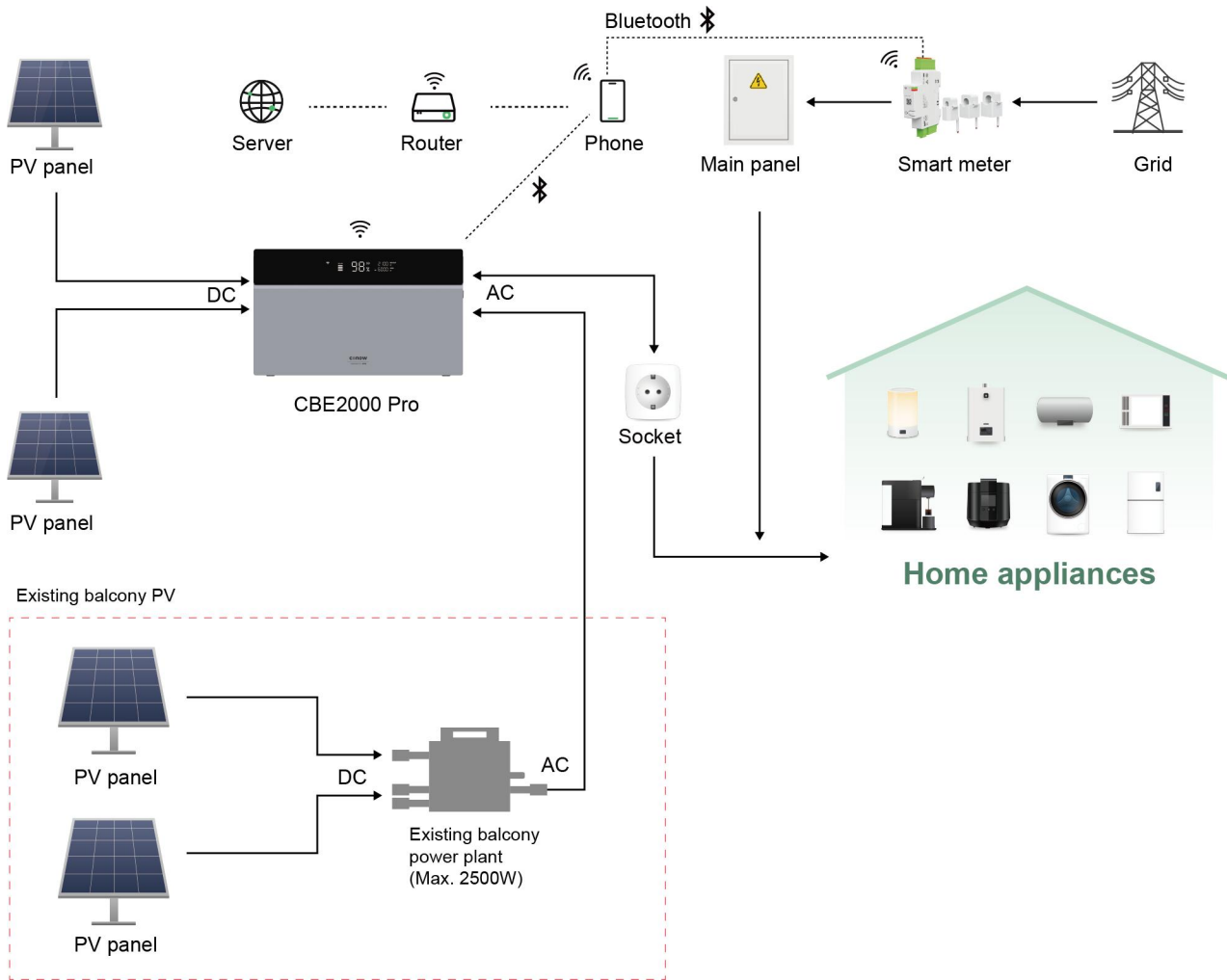

**NOTICE**

- CBE system supports integration with existing balcony power plant via the bypass interface for excess power storage.

## 2.2 System Capacity

The system supports two configurations: main battery + 2048Wh expansion battery and main battery + 5120Wh expansion battery stack.

Figure 2-2 System Capacity

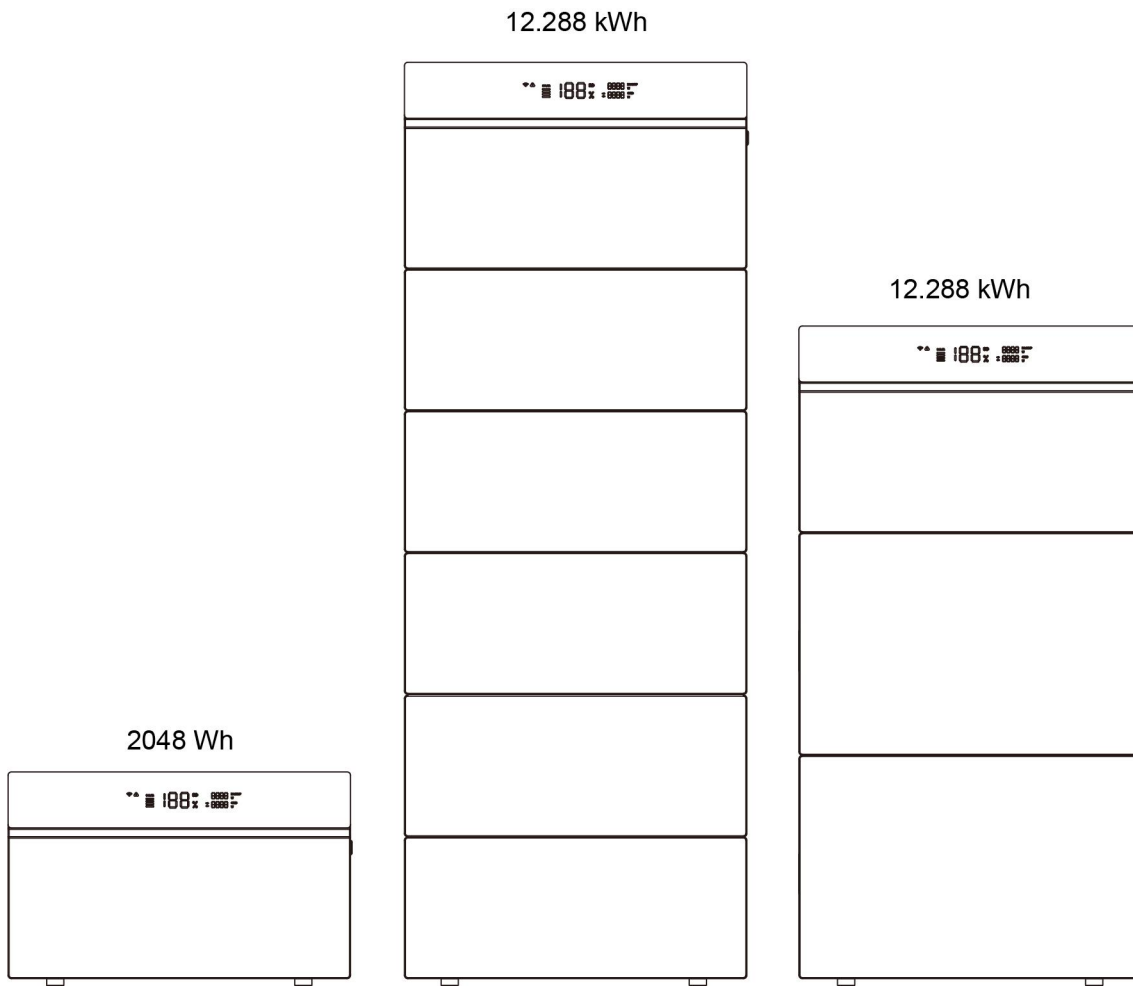

### 2.3 Interface Introduction

Figure 2-3 Energy storage system

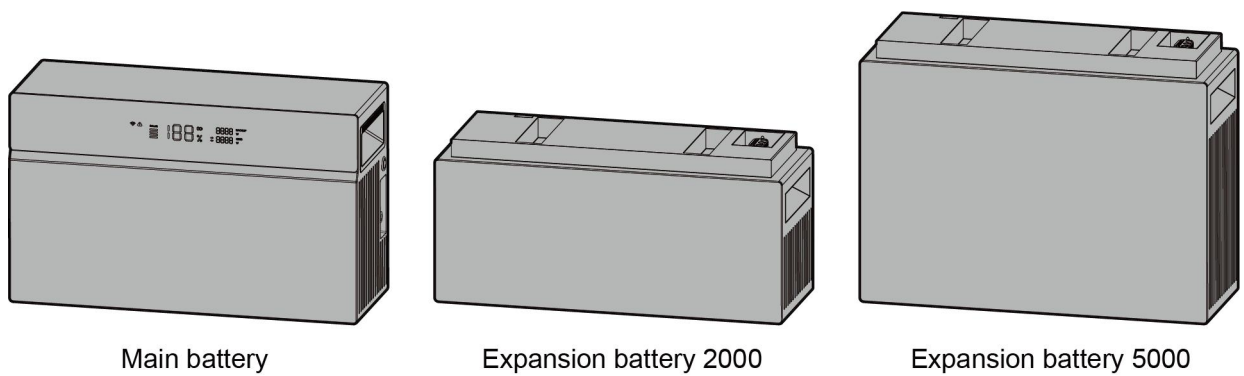

#### Main battery

Figure 2-4 Main battery

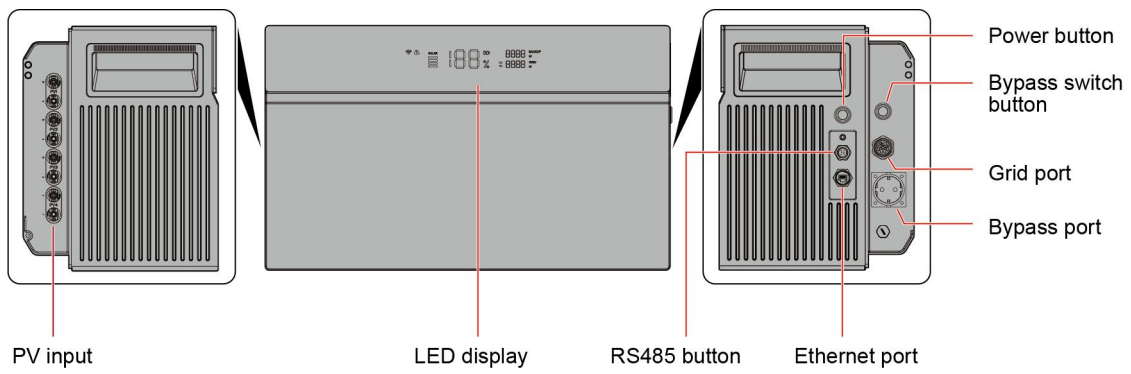

### LED Display

Figure 2-5 LED display

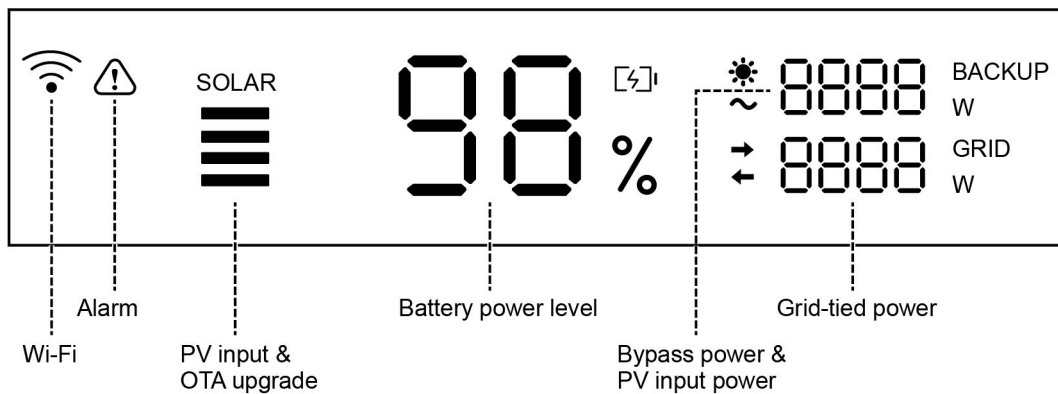



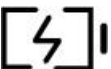



Table 2-1 Indication Light Description

Item	Name	Description
	Wi-Fi	On: Device has successfully connected to the network Flashing: Device is in network configuration mode Off: Device is connected to the network but not to the server.
	Alarm	On: Device has an active alarm
	Solar	On: Displays the number of connected MPPT inputs Flowing lights: Device is undergoing OTA firmware update
	Battery power	Real-time display of battery level information
	Charge status	On: Battery is currently charging
	PV input power	On: Real-time display of PV input power information

~ 8888 BACKUP W	Bypass power	On: Real-time display of bypass status power information
→ 8888 GRID W	On-grid output	On: Real-time display of grid-connected power information
← 8888 GRID W	On-grid input	On: Real-time display of grid input power information

## Function Description

**SPI Self-Test:** After connecting the device to mains power, press the power button to turn on the device, which will then perform a self-test. The self-test results can be viewed in the message center of the APP.

## Button Controls

### Power button:

- Power On: Press the power button for 1 second until the indicator light turns on.
- Power Off: Press and hold the power button for 2-5 seconds. The indicator light will turn off.
- Network Configuration: When the device is power on, press and hold the power button for 7~10 seconds. The LED display and indicator light will turn off after 2 seconds. Keep holding the button until the LED display and indicator lights on again. . Once the network configuration is done, the light will remain on and the Wi-Fi icon on the LED display will start to flash.

### Bypass switch button:

- Enable/disable bypass port.

### Note:

- After the device is powered on, the LED display will turn on by default when a person is within approximately 2 meters in front of the device. Once the person walks away, the lights will turn off after about 30 seconds.
- When the device is in an undervoltage or low state of charge (SOC) condition, pressing the power button will temporarily illuminate the indicator lights. If no further action is taken, the lights will automatically turn off after 20 seconds.

## 2.4 Technical Specifications

Table 2-2 Technical specifications

Model	CME03-2BS204	CME03-2BS204-07	CME03-2BS204-08	CME03-2BS204-19
<b>Battery</b>				
Capacity	<ul style="list-style-type: none"> <li>• Main battery: 2048Wh</li> <li>• Expansion battery 2000: Max. 5*2048Wh</li> </ul>			

Model	CME03-2BS204	CME03-2BS204-07	CME03-2BS204-08	CME03-2BS204-19
	<ul style="list-style-type: none"> <li>Expansion battery 5000: Max. 2*5120Wh</li> <li>Total capacity: Max. 12288Wh</li> </ul>			
Voltage Range	43.2 V - 57.6 V			
Rated Voltage/capacity	51.2 V/40 Ah			
Rated Power(Single device)	1800W			
Charge Current	<ul style="list-style-type: none"> <li>Main battery: Max. 40 A</li> <li>Expansion battery 2000: 40 A</li> <li>Expansion battery 5000: 60 A</li> </ul>			
Discharge Current	<ul style="list-style-type: none"> <li>Main battery: Max. 45 A</li> <li>Expansion battery 2000: 45 A</li> <li>Expansion battery 5000: 65 A</li> </ul>			
Standard Charge Current	20A			
Standard Discharge Current	20A			
Standard Charge Voltage	57.6 V			
Upper limit Charging Voltage	57.6 V			
End-of-discharge Voltage	43.2 V			
Life Cycle (Times)	> 6000 (25°C)			
Battery Type	LiFePO4			
<b>PV Input</b>				
Input Power	4×650 W			
Input Voltage	16 V - 60 V			
Max. Input Current	18±0.5 A			
Short Current	4×20 A			
Number of MPPTs	4			
Max. Inverter Feedback Current	0 A			
DC Overvoltage Class	II			
<b>On-grid Terminal (AC)</b>				
On-grid Output Power	2500W max.	799W	800W	1999W
On-grid Input Power	2500 W max.			
Output Voltage Range	176~264 VAC			
AC Frequency	50 Hz			
AC Nominal Input/Output Voltage	L+N+PE 220V/230V AC			
Max. Input Current	11 A			
Max. Output Current	11 A	3.5 A	3.5 A	9 A
Total Harmonic Distortion	Typ. < 3%, Max. < 5%			
Power Factor	0.8 lagging - 0.8 leading			
<b>Off-Grid Terminal (AC)</b>				
Rated Output Power	2500W			
AC Output Current	Max. 11 A			
Rated AC Output Current	11 A			
AC Nominal Output Voltage	L+N+PE 220V/230V AC			

<b>Model</b>	<b>CME03-2BS204</b>	<b>CME03-2BS204-07</b>	<b>CME03-2BS204-08</b>	<b>CME03-2BS204-19</b>
AC Frequency	50 Hz			
Backup Output Peak	200% 2s			
EPS Switching Time	< 10ms			
<b>Environmental and Mechanical</b>				
Communication	Wi-Fi & Bluetooth LE; Ethernet; RS485			
Storage Temperature Range	-20°C to +55°C			
Charge Temperature Range	0°C to +50°C			
Discharge Temperature Range	-20°C to +55°C			
Operating Humidity	≤ 85%RH (non-condensation)			
Storage Humidity	10% - 85%RH (non-condensation)			
Enclosure Rating	IP65			
Cooling Mode	Natural convection			
Dimensions (W × H × D)	<ul style="list-style-type: none"> <li>• Main battery: 580 mm × 350 mm × 275 mm</li> <li>• Expansion battery 2000: 580 mm × 268 mm × 230 mm</li> <li>• Expansion battery 5000: 580 mm × 456.5 mm × 230 mm</li> </ul>			
Weight	<ul style="list-style-type: none"> <li>• Main battery: 29.5 kg</li> <li>• Expansion battery 2000: 25.5 kg</li> <li>• Expansion battery 5000: 49.5 kg</li> </ul>			
Noise	≤ 45dB			
Maximum Altitude Rating	≤ 2000 m			
Warranty	10 Years			
Self-consumption (bypass off)	11.5 W			
Pollution Degree	PD III			
Topology Type	Isolation			
<b>Efficiency</b>				
Max. Output Efficiency	94.8%			
MPPT Efficiency	99.5%			
Battery Charge Efficiency	94.5%			
<b>Protection</b>				
Protective Class	Class I			
Over Voltage Category	AC.OVC III, PV.OVC II			
Inverter Topology	Isolated			
Overvoltage Protection	Yes			
Undervoltage Protection	Yes			
Over-frequency Protection	Yes			
Underfrequency Protection	Yes			
Short Circuit Protection	Yes			
Reverse Connection Protection	Yes			
Over Temperature Protection	Yes			
Anti-Islanding Protection	Yes			
<b>Safety certification</b>				
IEC62109-1, IEC61000-6-1/-3, IEC61000-3-2/-3, IEC62619, EN 50549-1/-10, NEN EN50549-1+BWB				

<b>Model</b>	<b>CME03-2BS204</b>	<b>CME03-2BS204-07</b>	<b>CME03-2BS204-08</b>	<b>CME03-2BS204-19</b>
R0037940 Netcode, ETSI EN300328, ETSI EN301489-1/17, OVE-directive R25:2020-3 TOR Erzeuger Type A, VDE 4105, VDE 0124, NF50549-10, UN 38.3, C10/11, CEI 0-21, IEC61000-4, IEC 62920				

# 3 Product Installation

## 3.1 Unboxing and Inspection

Before opening the box, please check the outer packaging for visible damage, such as deformation, broken holes, or other signs of possible internal damage, and check the product model number. If there are any packaging abnormalities or product model discrepancies, do not open the box and contact the product distributor promptly.

After unpacking the equipment, check that the product matches the bill of materials and that there is no visible external damage or missing materials. If any material is missing or there is any damage, please do not use it and contact the product distributor promptly.

Figure 3-1 Packing list (Main battery)











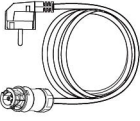
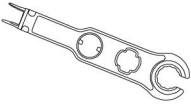
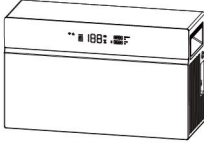

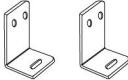
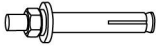
 <p>Grid-tied power cable</p>	 <p>Tool</p>	 <p>Main battery</p>	 <p>Quick start guide</p>
 <p>Main battery bracket</p>	 <p>Expansion bolt (M5)</p>	 <p>Screw (M5)</p>	

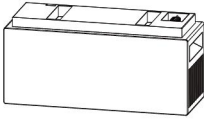
Figure 3-2 Expansion battery packing list (The following accessories must be ordered separately.)

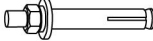
 <p>Expansion battery</p>	 <p>Battery bracket</p>	 <p>Expansion bolt (M5)</p>	 <p>Screw (M5)</p>
--	--	---	---

## 3.2 Prepare Tools

Table 3-3 Tools

 <p>Phillips screwdriver</p>	 <p>Electric drill</p>	 <p>level ruler</p>	 <p>Marking pen</p>
---	---	---	--

## 3.3 Installation Environment Requirements

The installation and use of the device must comply with local laws and regulations as well as the provisions for lithium battery products in relevant international, national, and regional standards.

The device should not be installed in enclosed, non-ventilated areas where there are no proper fire safety measures or where it is hard for fire personnel to reach.

Do not place flammable or explosive items near the device.

The location of the device should avoid direct sunlight, rain, and snow accumulation.

The installation location of the device should avoid water accumulation and should be away from water sources like faucets, drain pipes, sprinklers, etc. to prevent water seepage.

The height of the device installation should be convenient for operation and maintenance, ensure that device indicator lights and all labels are easy to see.

## 3.4 Install Equipment



- Before installing the energy storage system, please make sure the battery module is turned off. Installing the battery module while it is powered is not allowed as it could lead to the risk of electric shock.

### 3.4.1 Installation (Main battery)

Step 1 Place the main battery in an appropriate location.

Figure 3-5 Installing the main battery

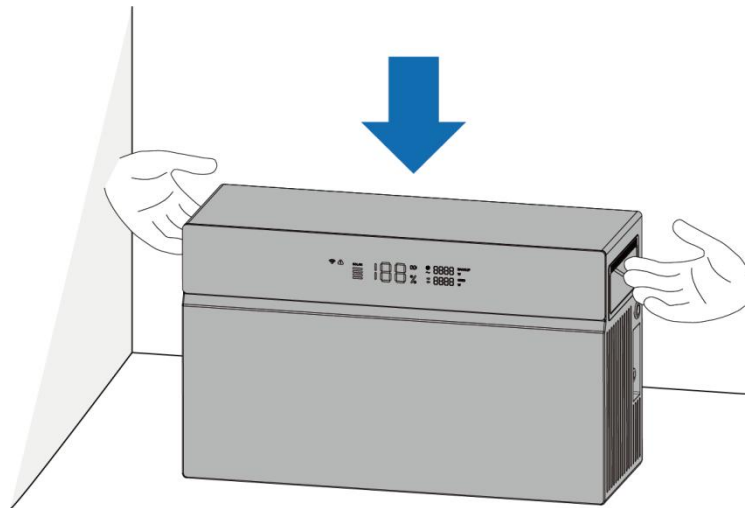

### 3.4.2 Installation (Main battery and expansion battery)

 DANGER

- To protect yourself and the equipment, ensure the system is powered off before installing or adding expansion batteries. Installation while the system is powered on is not covered under warranty.
- 

Step 1 Remove the waterproof cover from the bottom of the main battery.

Step 2 Install the removed waterproof cover onto the bottom of the expansion battery.

 NOTE

- Only the expansion battery installed at the very bottom requires the waterproof cover to be installed.
- 

Step 3 Install the L-shaped structural bracket.

Step 4 Mark and drill holes.

Step 5 Secure the expansion battery.

 NOTE

- When configuring multiple expansion batteries, install the other expansion batteries in the same manner.
- 

Step 6 Install the main battery mounting bracket.

Step 7 Mark and drill holes.

Step 8 Secure the main battery.

Figure 3-6 Installing the balcony ESS

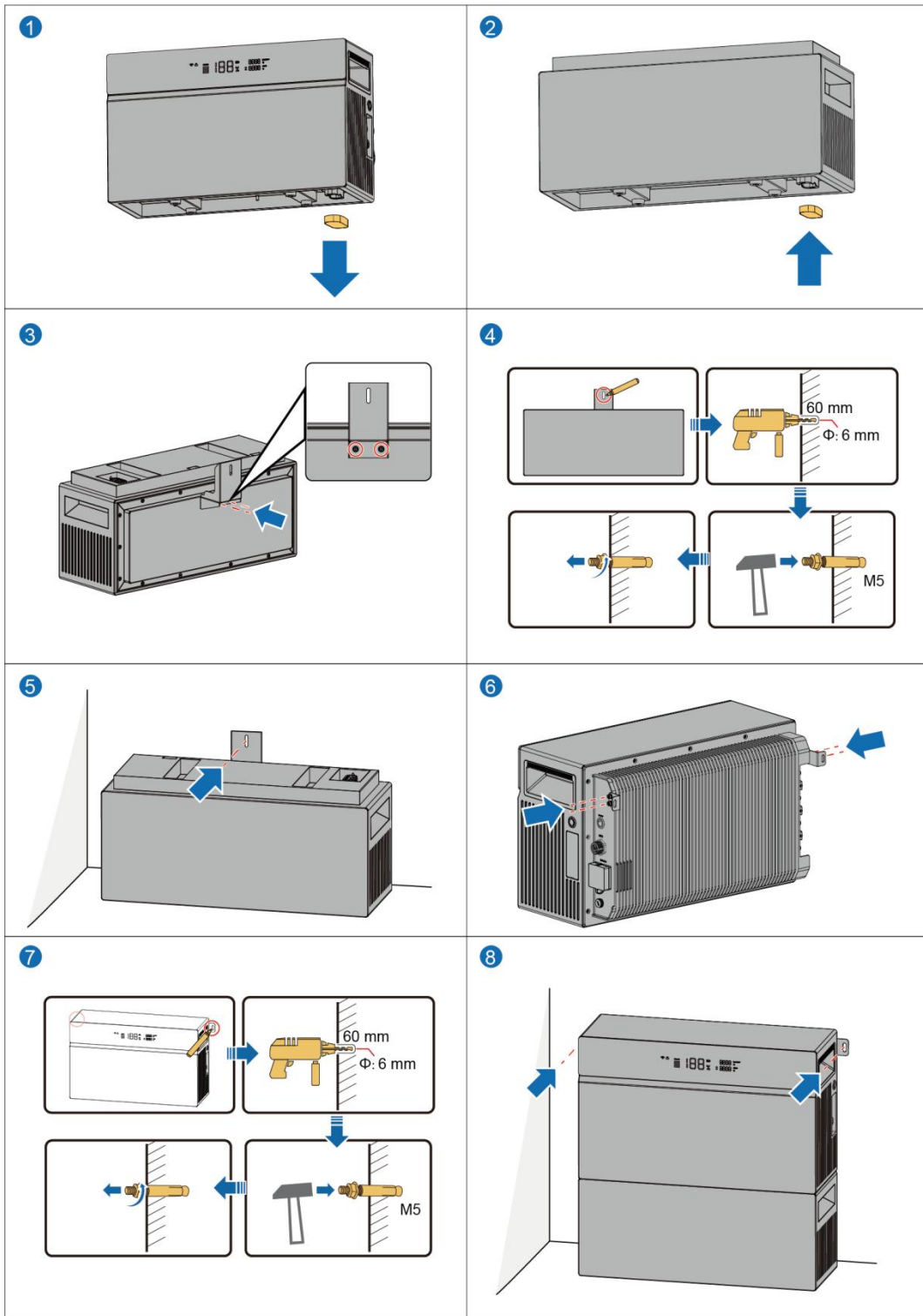

# 4 Product Wiring

 WARNING

- Ensure that unused PV input ports on the device are sealed with waterproof caps.
- Do not connect the same set of PV connectors to different PV input ports. For example, it is prohibited to connect the positive connector of PV1 to the input port of PV2.
- Never connect two or more panels in series, because this causes the input voltage to exceed 60V and will damage the equipment.
- Before installing the cables, ensure that all batteries are powered off.

Figure 4-1 Prohibition of PV connector cross-connection

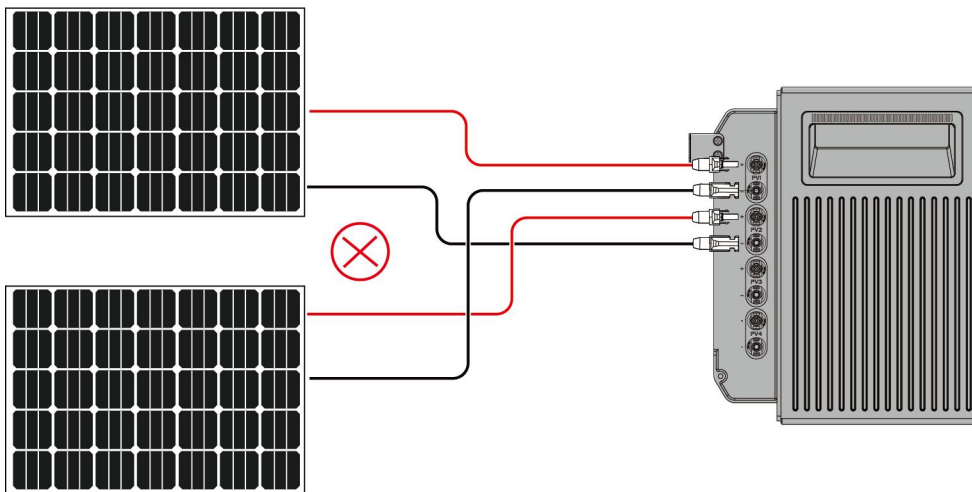
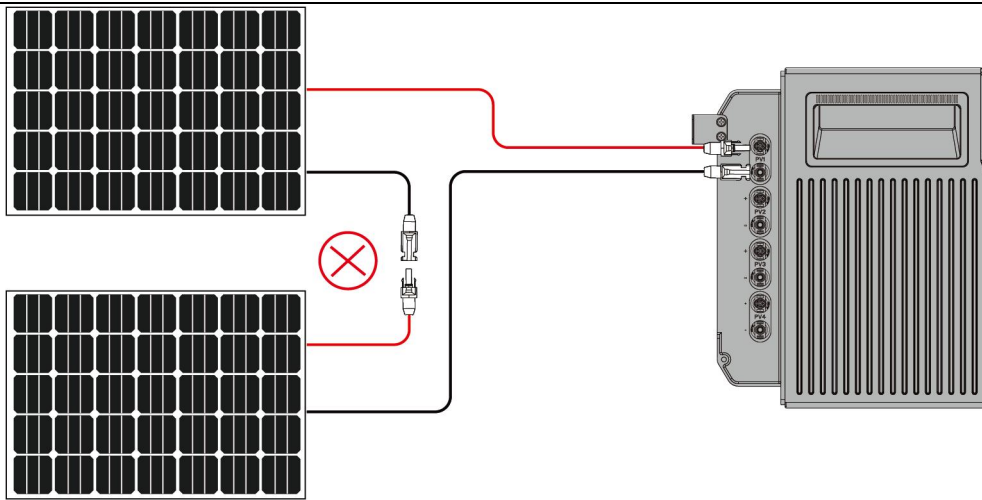

Figure 4-2 Do not connect in series



### 4.1 PV Panels Wiring

Figure 4-3 Direct connection (Up to 4 PV panels)

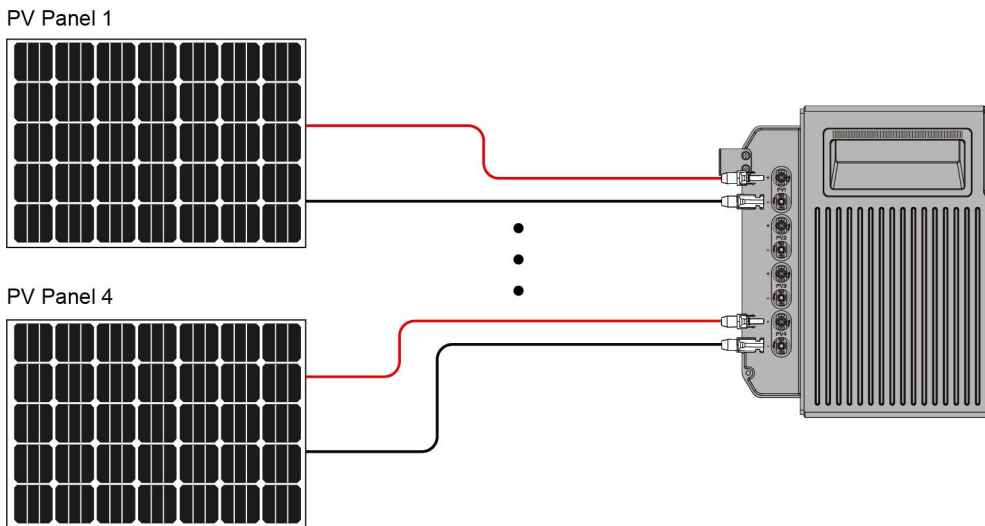
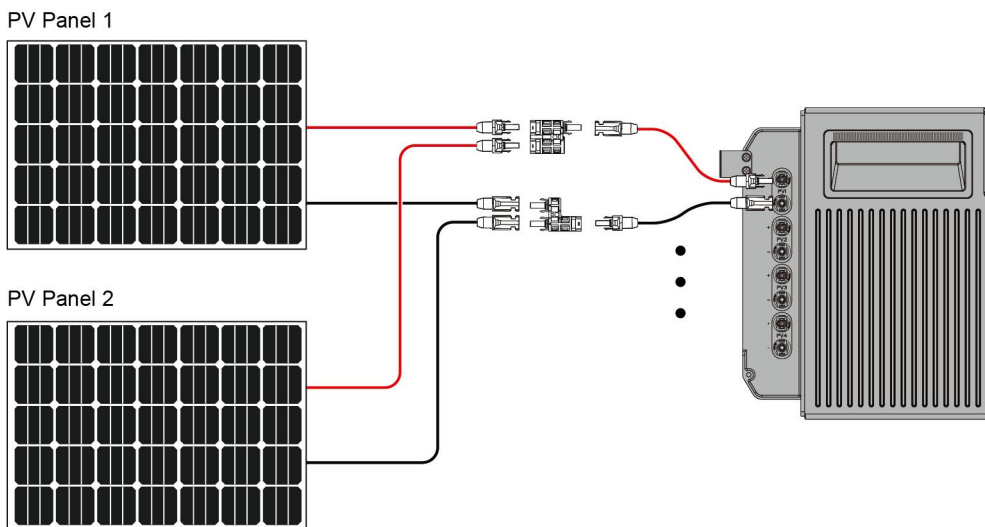

Figure 4-4 Parallel connection (Up to 8 PV panels)



## 4.2 Install the Cables (New Installation)

Step 1 Install the protective grounding cable.

Step 2 Install the PV input cables.

Step 3 Install the grid-tied power cable.

Step 4 Install the backup power cable.

Figure 4-5 Installing the cables

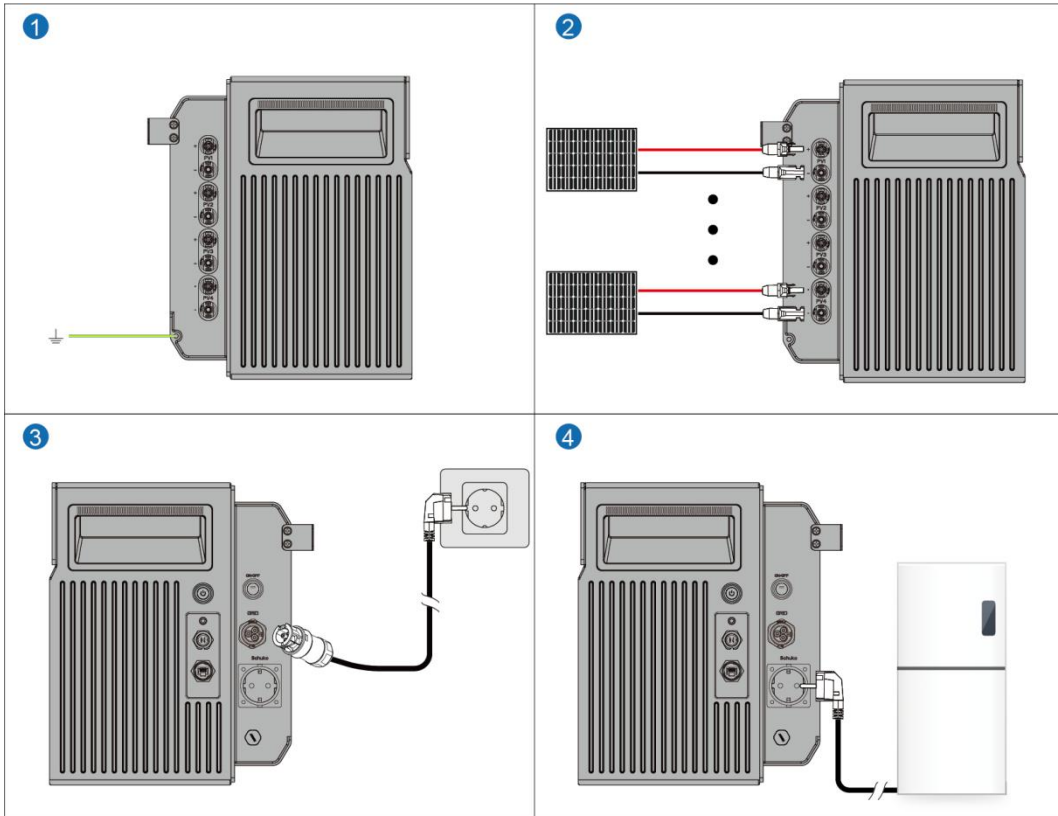
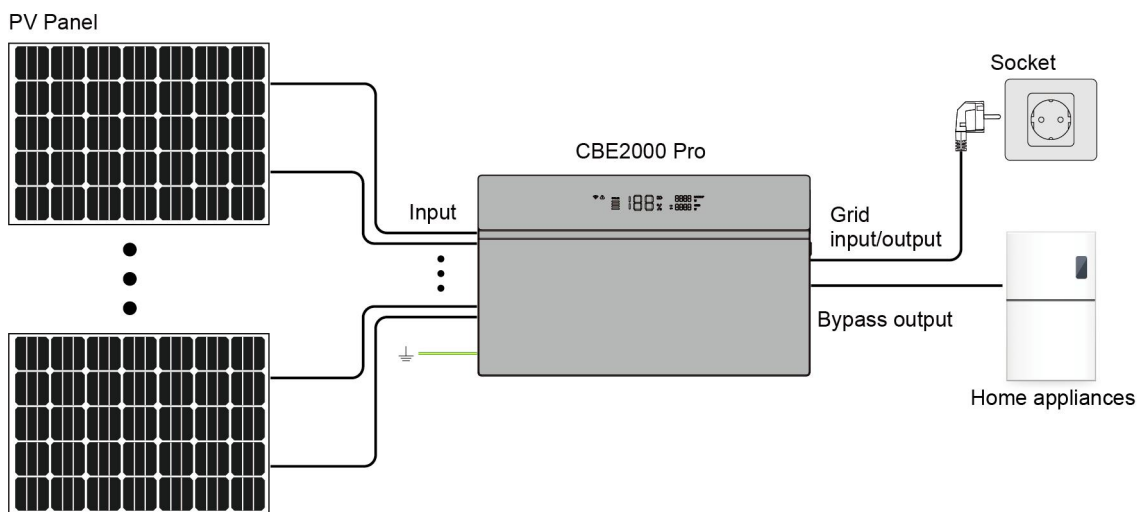

Figure 4-6 Wiring completion diagram



## 4.3 Install the Cables (Existing PV System Retrofit)

Step 1 Install the protective grounding cable.

Step 2 Install the PV input cables.

Step 3 Install the grid-tied power cable.

Step 4 Install the existing micro inverter power output cable.

Figure 4-7 Installing the cables

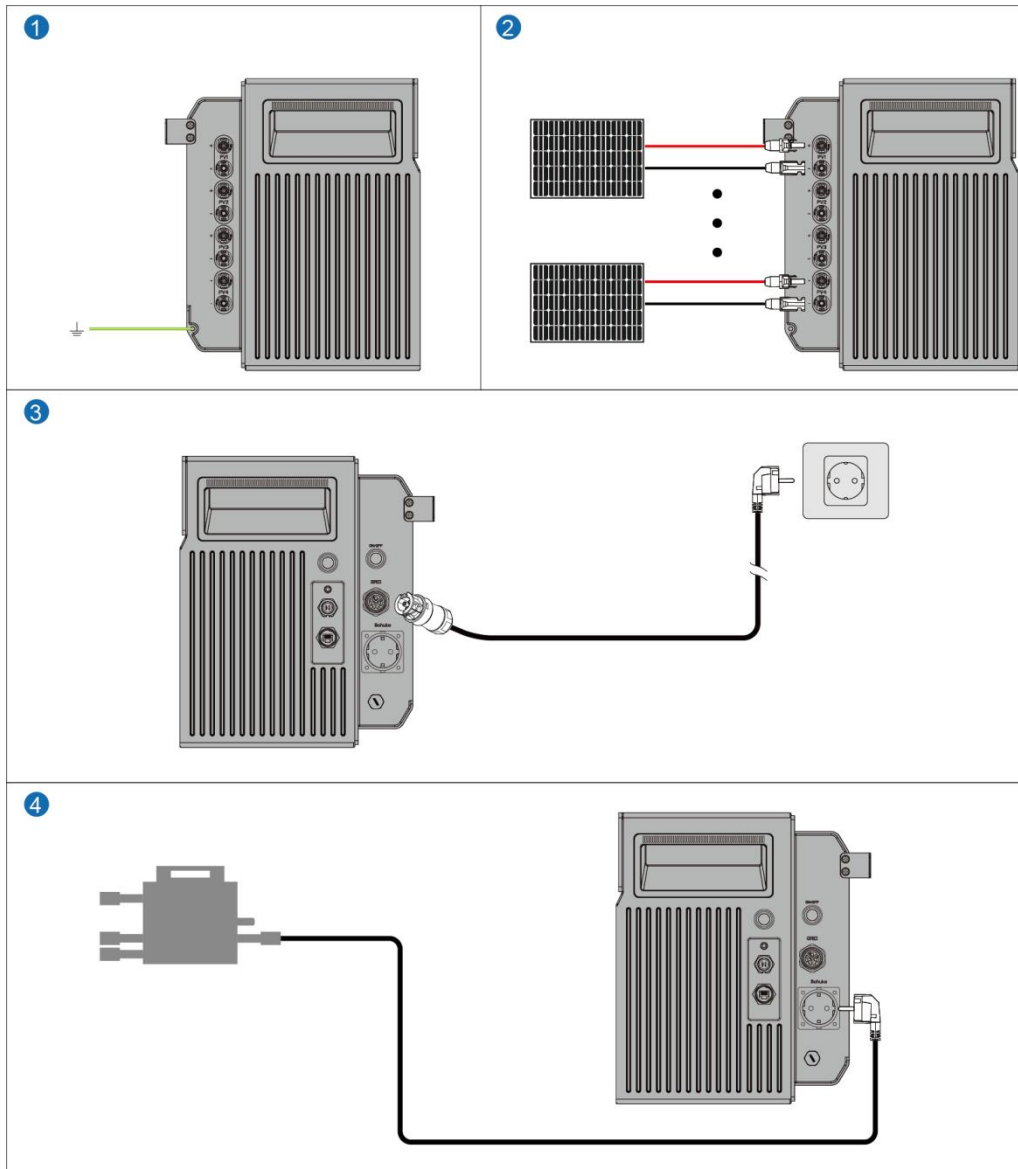
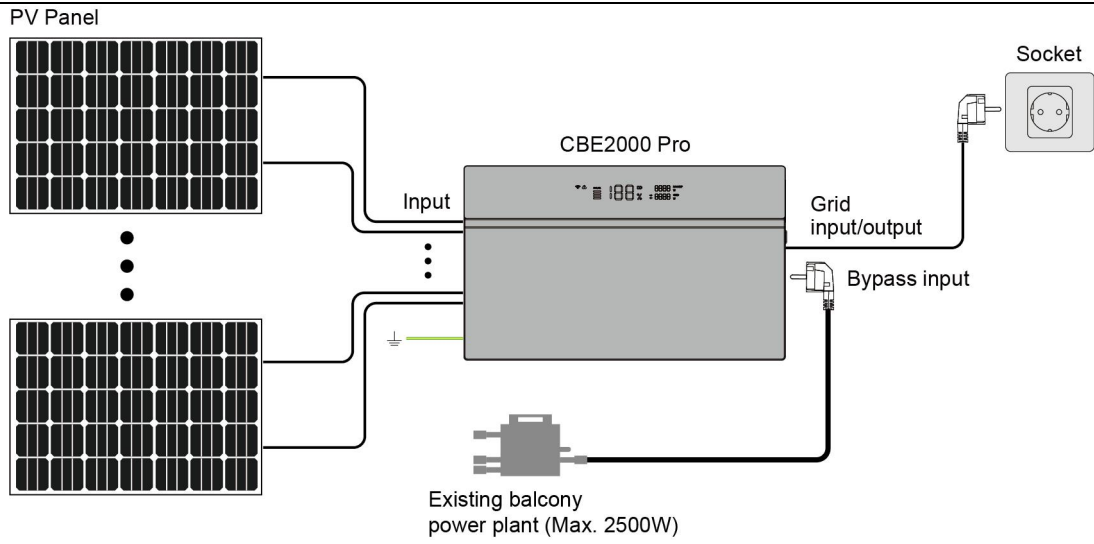

Figure 4-8 Wiring completion diagram



# 5 Product Network Configuration

---

Due to periodic upgrades of the App and device versions, please refer to the actual pages displayed in your current version. The images shown in this section are for reference only.

## 5.1 Download the CONOW ECO App

- Scan the QR code or search for **CONOW ECO** in the Google Play Store or Apple App Store. After downloading, please register and log in to the App.
- Scan the QR code on the device to download the App.



CONOW ECO

### NOTE

- If you have already downloaded the **SmartLife** or **Tuya** App, you may use your existing App directly, as its operation is identical to that of **CONOW ECO**.
- 

## 5.2 Log in / Sign up

### Sign up

Step 1 Tap the Sign Up button, choose your country/region, enter your email/mobile number, and tick the box to accept the Privacy Policy and User Agreement.

Step 2 Then tap “Get Verification Code”, fill in the verification code you received, your account will be created.

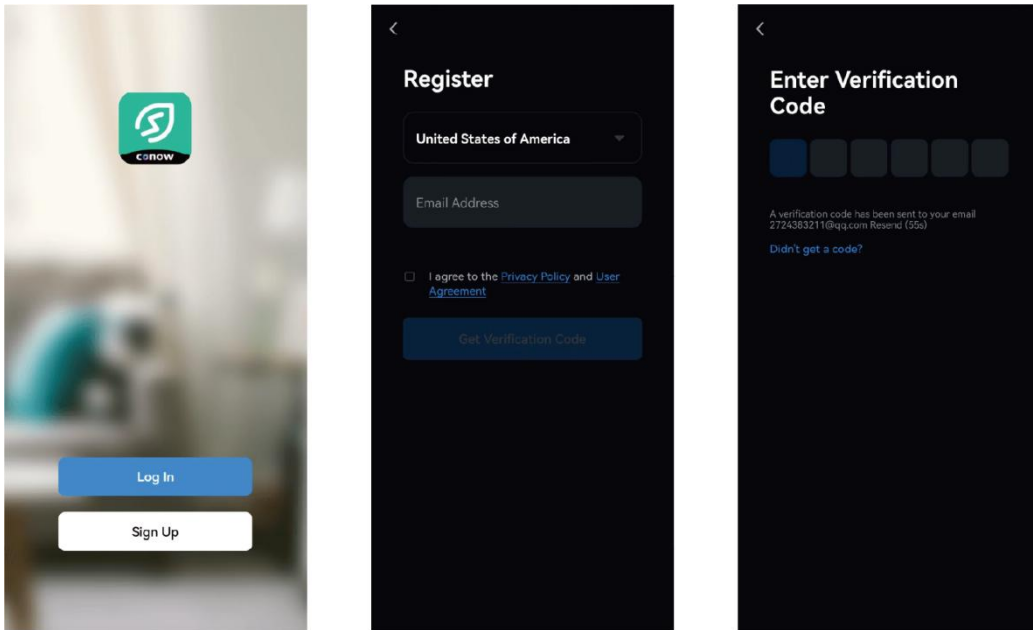

### Log in

Step 1 Tap "Log In", enter your password, accept the Privacy Policy, and confirm to complete login.

Step 2 Tap the "Log In" button, the App guide map will be prompted if it's your first login.

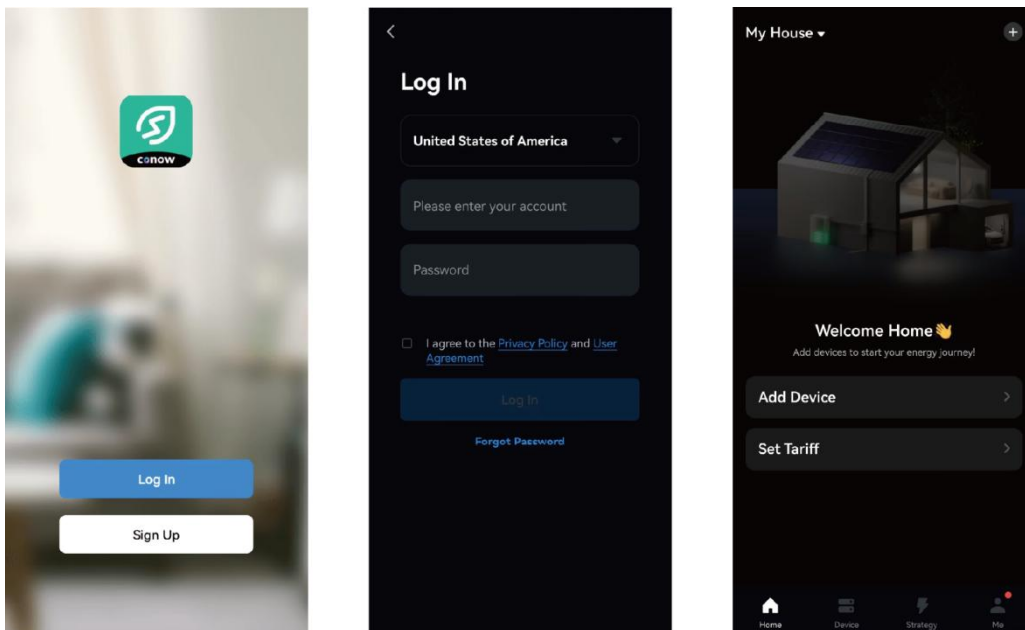

### App Logout

Step 1 Go to "My" → Settings, tap "Sign out", then confirm when prompted.

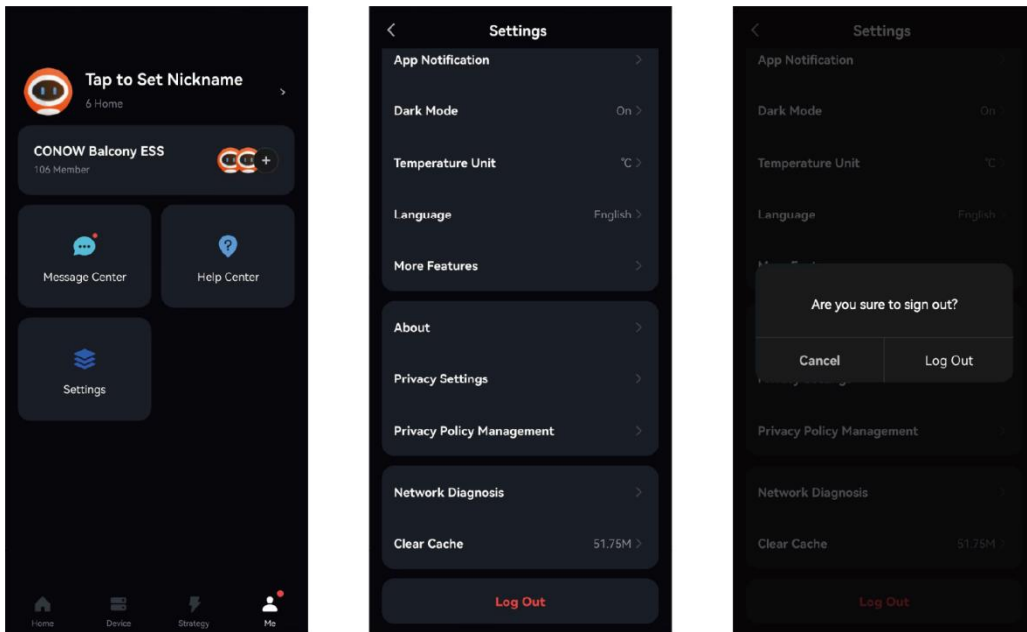

### 5.3 Device Network Configuration

- Step 1 Press the power button to turn on the device (the button indicator light is on).
- Step 2 Press the bypass switch button for 1 second to enable the bypass function (the button indicator light is on).
- Step 3 Check the LED display to confirm the device is in pairing mode (Wi-Fi icon flashing).
- Step 4 Press and hold the reset button on the smart meter for 5 seconds. The indicator light will begin to flash, indicating that the smart meter has entered network connection mode. (if a smart meter is purchased)
- Step 5 Open the App and click “Add” to add a device.

#### ⚠ NOTICE

- When adding a device, you need to enable Bluetooth and Wi-Fi on your phone, and the Wi-Fi must be 2.4 GHz.
- Use the same method to add a smart meter.

#### 🔍 NOTE

- When you have multiple smart devices in pairing mode, you can search for and add them all simultaneously in the App. The example below shows the process for adding a single device.

Figure 5-1 Adding device

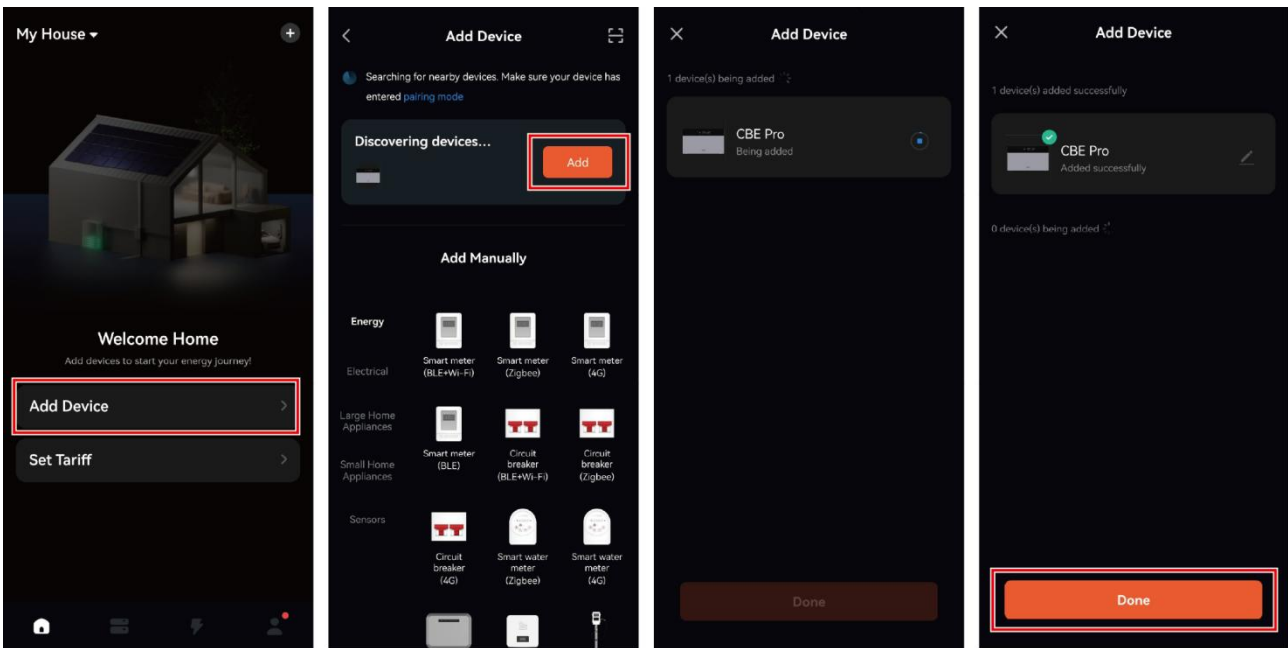

Step 6 Access the device page to view information and configure functional parameters based on your actual requirements.

**NOTE**

- The devices shown below are examples only. Refer to your actual devices.

Figure 5-2 Device page

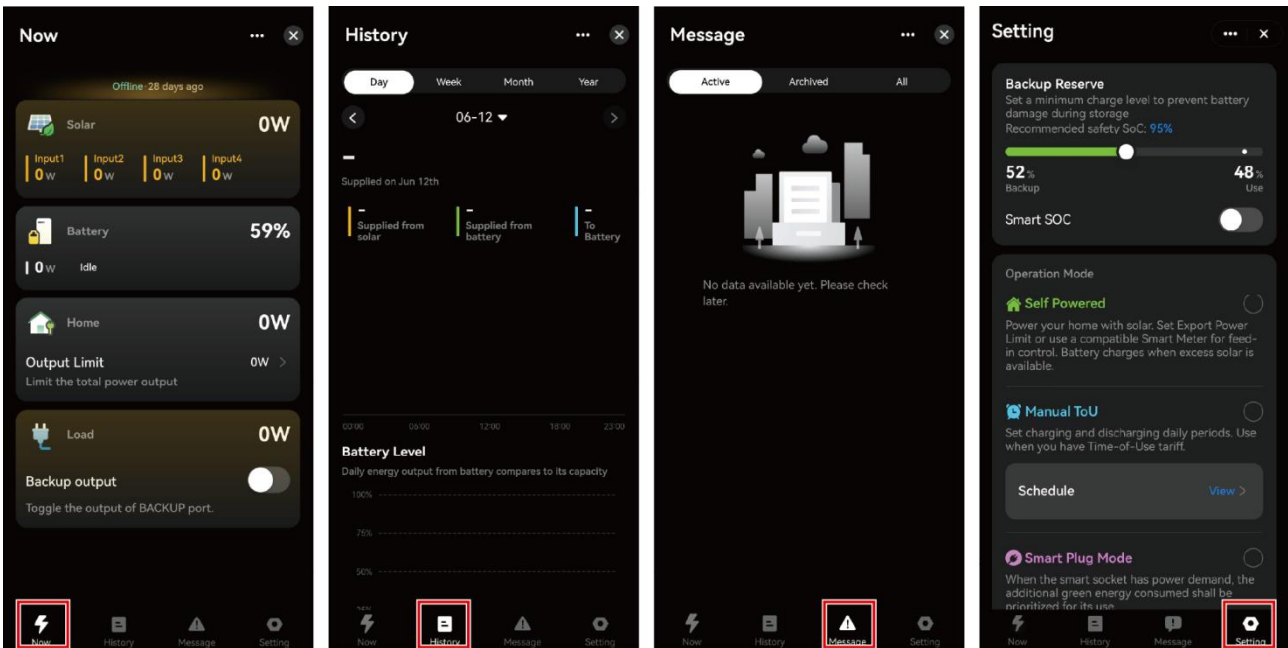

### 5.4 (Optional) Added Other Devices

Navigate to the Device page in the App, then tap the “+” icon located in the upper right corner and select “Add Device”. Before proceeding, make sure your smart device is in network configuration mode.



- The devices shown below are examples only. Refer to your actual devices.

Figure 5-3 Added Devices

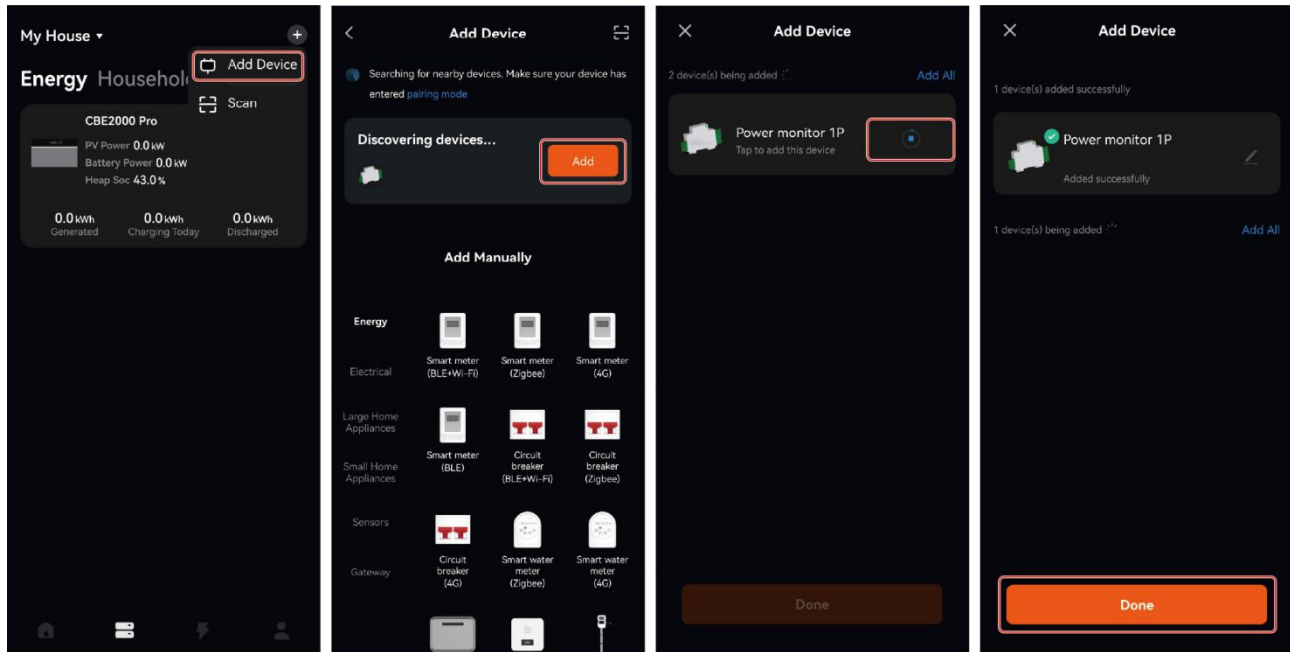

## 5.5 Introduction to Function Settings



- The system defaults to **Self Powered** mode, which can be changed according to actual usage requirements.
- Self Powered:** When there is PV input, the PV input is prioritized for grid connection; when there is no PV input, the battery is prioritized for supplying power to the load; when the battery discharges to the specified SOC, the mains power supplies the battery and the load.

### Function Introduction

Figure 5-4 Setting page

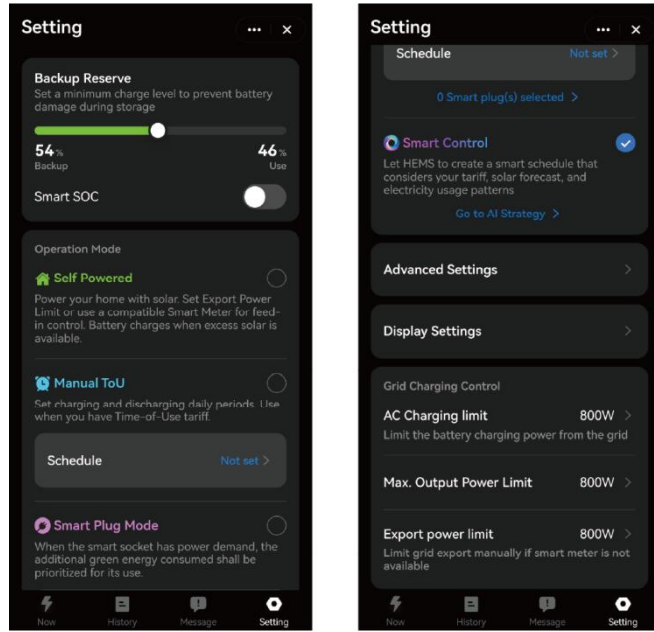

Table 5-1 Function Settings

Function	Description
<b>Backup Reserve</b>	<ul style="list-style-type: none"> <li>Set a minimum charge level to prevent battery damage during storage.</li> <li><b>Smart SOC:</b> Intelligently recommends backup power SOC based on seasonal patterns, weather forecasts, and electricity usage habits.</li> </ul>
<b>Self Powered</b>	Store the excess solar during the day and use after the sun goes down.
<b>Manual ToU</b>	Manually set time-of-use schedule.
<b>Smart Plug Mode</b>	When the smart socket has power demand, the additional green energy consumed shall be prioritized for its use.
<b>Smart Control</b>	Let HEMS to create a smart schedule that considers your tariff, solar forecast, and electricity usage patterns.
<b>Advanced Settings</b>	Connect Smart Meter, Enable Zero Export Function, and Limit Export Power.
<b>Display Settings</b>	Based on actual usage habits, configure the LED display to energy-saving mode, always-on mode, or manual control mode. The display power type can also be set.
<b>Grid Charging Control</b>	<ul style="list-style-type: none"> <li><b>AC Charging Limit:</b> Set the charging power from the grid to the battery.</li> <li><b>Max. Output Power Limit:</b> Max. power of grid-tied output from the device.</li> <li><b>Export Power Limit:</b> Flexibly set the grid-tied output power of the device.</li> </ul>

Figure 5-5 Display settings and Advanced settings

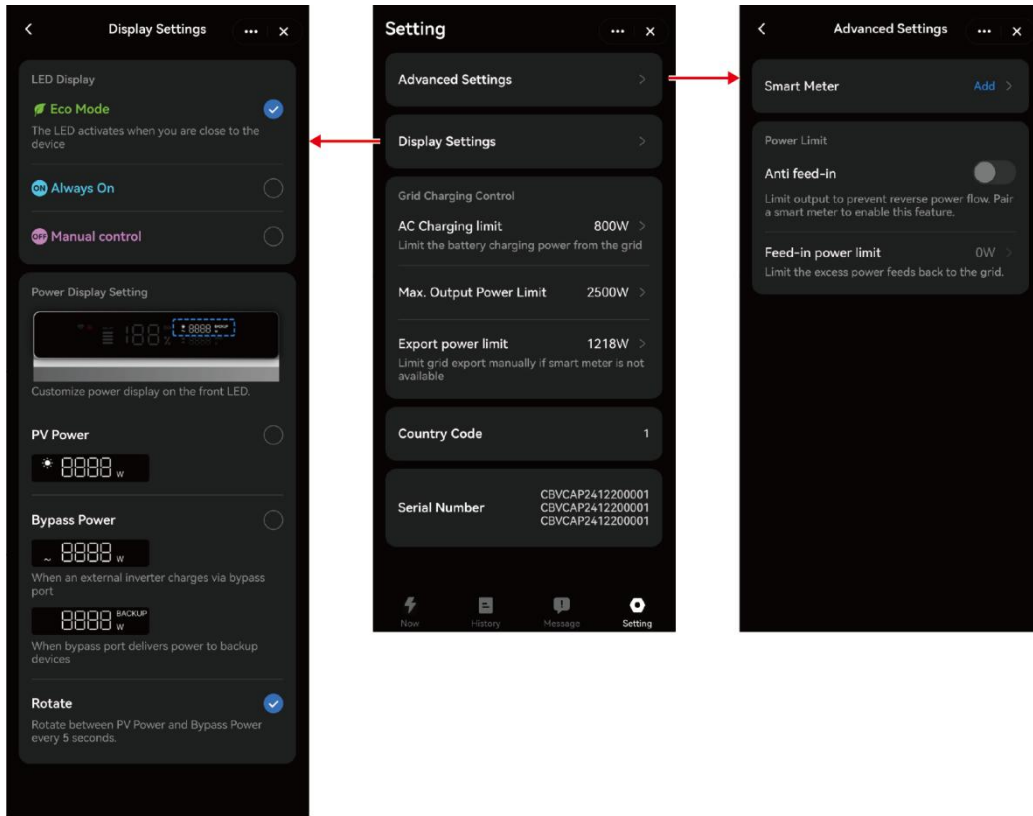

Table 5-2 Advanced Settings

Function	Description
<b>Smart Meter</b>	Connect the smart meter to the CBE2000 pro.
<b>Anti Feed-In</b>	Limit output to prevent reverse power flow. Pair a smart meter to enable this feature.
<b>Feed-in power limit</b>	Limit the excess power feeds back to the grid,

Table 5-3 Display Settings

Function	Description
<b>Eco Mode</b>	The LED activates when you press the button or when the proximity sensor detects movement.
<b>Always On</b>	The LED display screen remains in an always-on state.
<b>Always Off</b>	The LED display screen remains in an always-off state and can be manually activated.
<b>Power Display Setting</b>	Customize power display on the front LED.

## Manual ToU

Manual setting of battery charging/discharging times and target battery level values.

Figure 5-6 Manual ToU settings

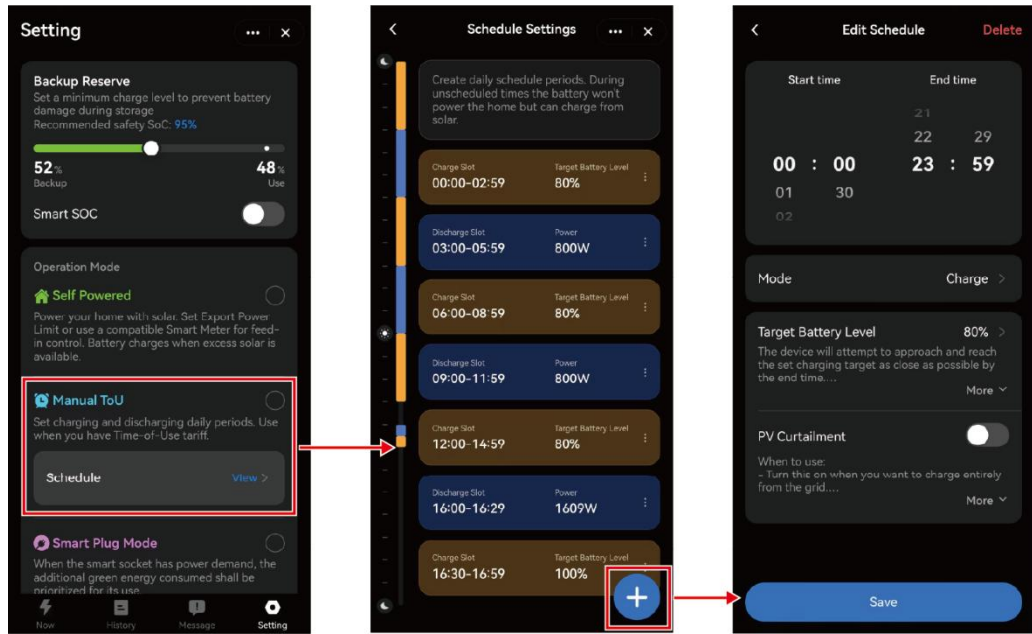

### Smart Plug Mode

When the smart socket has power demand, the additional green energy consumed shall be prioritized for its use.

This mode is only supported when a smart plug is configured.

Figure 5-7 Smart Plug Mode settings

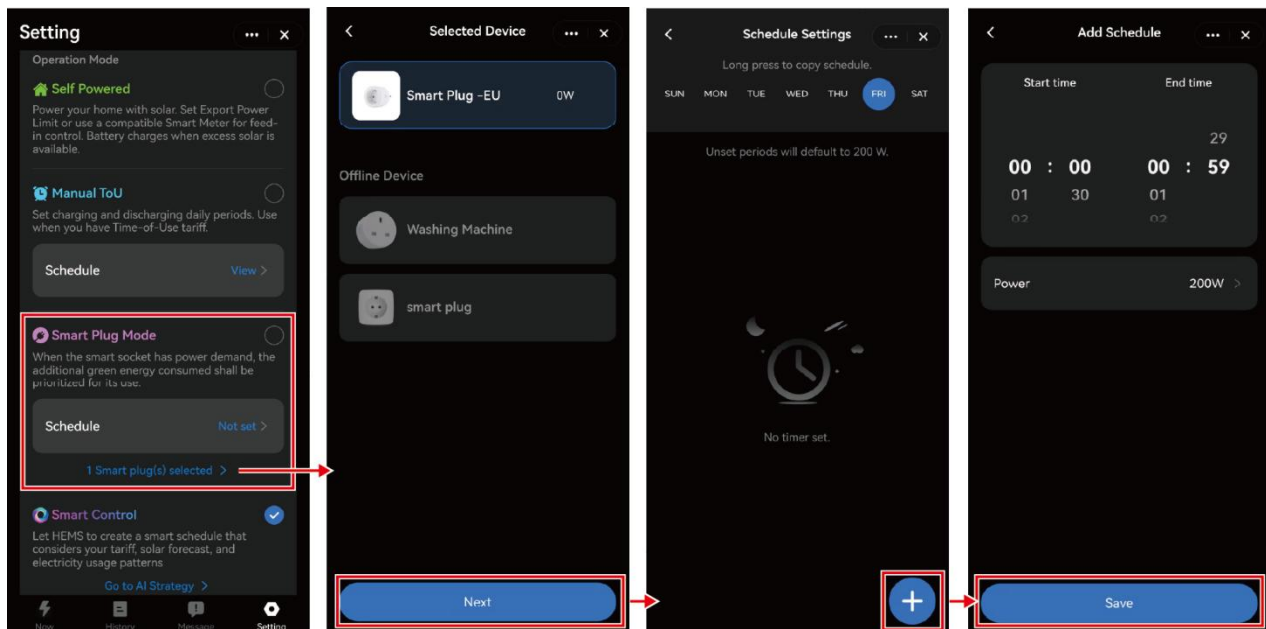

### Smart Control

Let HEMS to create a smart schedule that considers your tariff, solar forecast, and electricity usage patterns.

Figure 5-8 Smart Control settings

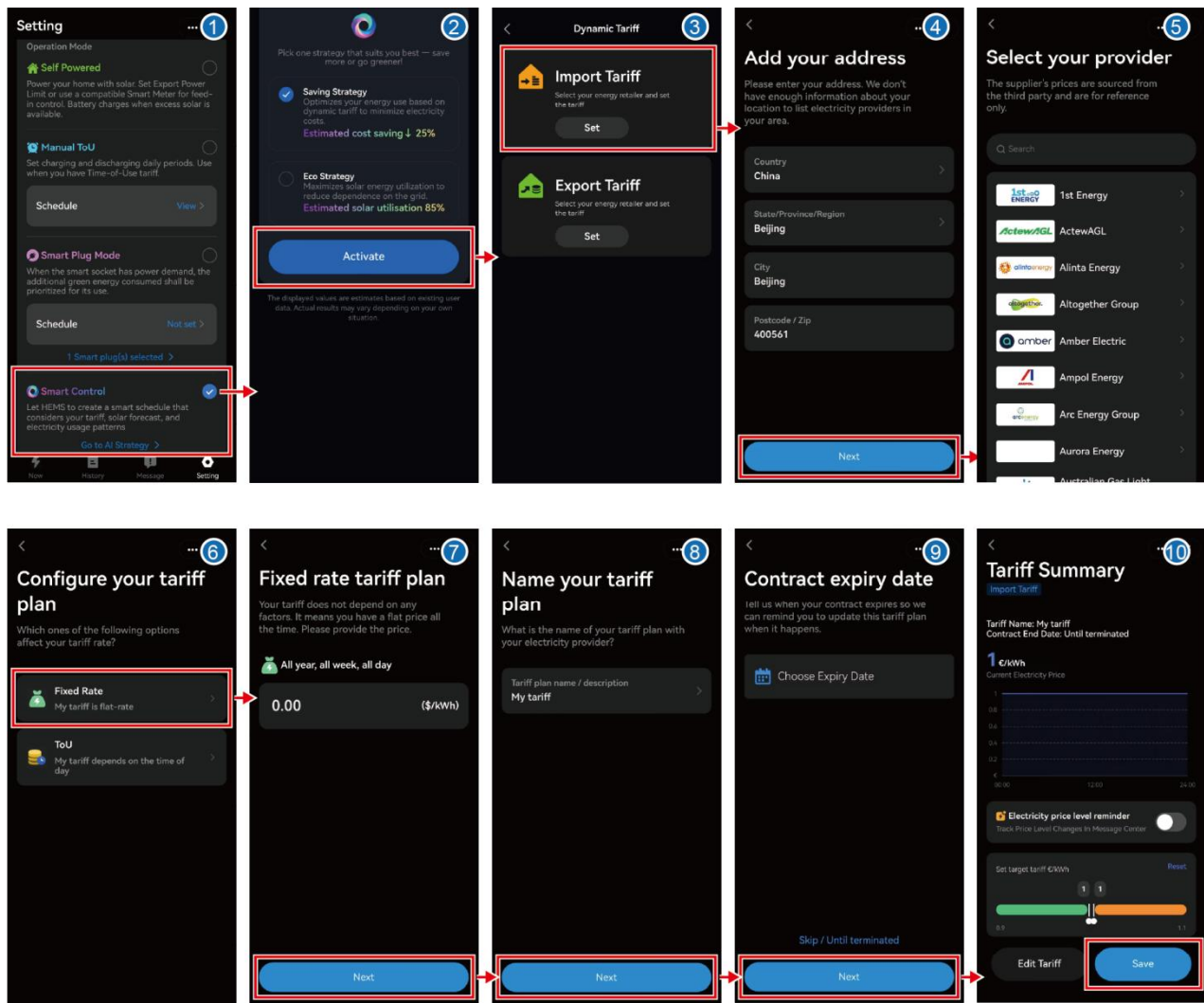

### Anti Feed-in Function

**NOTICE**

- After connecting the smart meter, the anti feed-in function will be automatically enabled.
- You need to first add the smart meter in the app, and then go to the device's advanced settings page to add the smart meter.

Figure 5-9 Enable anti feed-in function

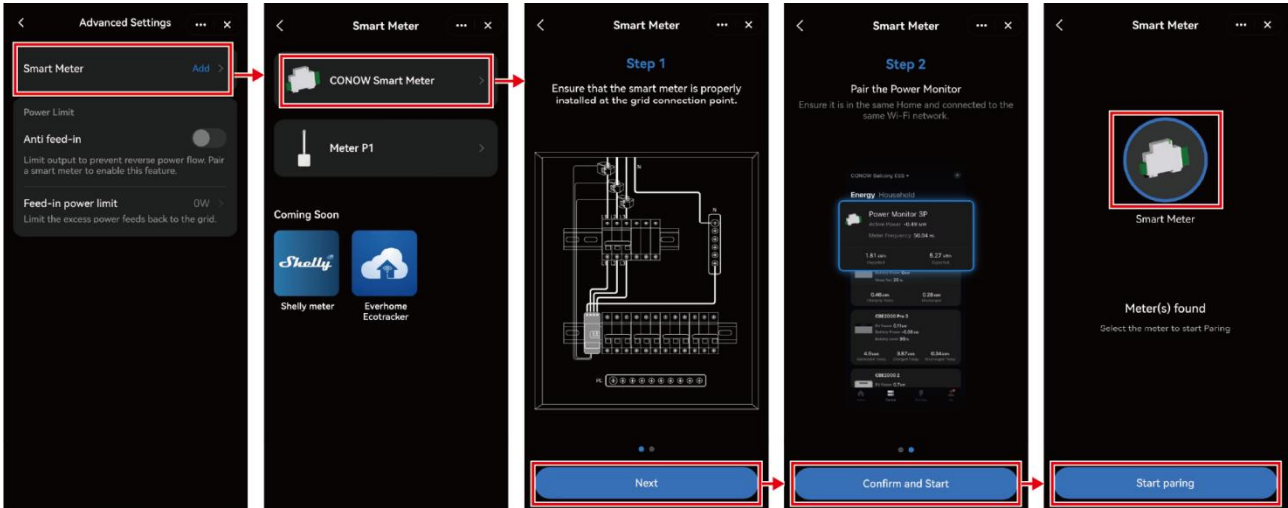

## Bypass Load

Switch the status of the Bypass port based on actual conditions.

Figure 5-10 Bypass Load settings



# 6 Product Maintenance

## 6.1 Alarm Handling

The following alarm information is at a critical level and requires immediate attention. Non-critical alarm information will automatically recover when the corresponding conditions are met.

0104, 0109, 0110, 0111, 0112, 0116, 0117, 0118, 0119, 0120, 0121, 0122, 0123, and 0124 are alarm codes for main battery. When multiple expansion batteries are stacked, the corresponding alarm codes are 01XX-06XX, where 01XX represents the main battery, and 02XX-06XX represent the expansion batteries from top to bottom respectively. (Example: Main battery + 5 expansion batteries - the main battery alarm code is 0104, the topmost expansion battery is 0204, and so on downward, with the bottommost expansion battery being 0604.)

Alarm Code	Fault Name	Cause	Solution Measures
0104-0604	Pack Undervoltage	Battery pack total voltage is below the lower limit	Charge the battery immediately. If charging fails, contact support.
0109-0609	Charge Overcurrent Level 1	Charging current exceeds the Level 1 threshold	Try restarting and observe if it recovers. If not, contact support.
0110-0610	Charge Overcurrent Level 2	Charging current severely exceeds the limit	Try restarting and observe if it recovers. If not, contact support.
0111-0611	Discharge Overcurrent Protection	Discharge current exceeded the threshold and was protected	Try restarting and observe if it recovers. If not, contact support.
0112-0612	Discharge Overcurrent Level 2 Protection	Discharge current severely exceeded the limit and forced protection was triggered	Try restarting and observe if it recovers. If not, contact support.
0116-0616	Short-Circuit Protection	Short circuit detected on the DC side and protection activated	Power off immediately and check wiring/load. Restart to test. If not recovered, contact support.
0117-0617	NTC Failure	Temperature sensor error (open/short)	Try restarting and observe if it recovers. If not, contact support.

Alarm Code	Fault Name	Cause	Solution Measures
0118-0618	Cell Failure	A cell failed or is disconnected	Stop using the device and contact support promptly.
0119-0619	AFE Failure	Front-end sampling circuit failure	Power down and contact support for diagnostics.
0120-0620	Charge MOS Failure	Abnormal switching of charge MOS	Stop charging immediately and contact support.
0121-0621	Discharge MOS Failure	Abnormal switching of discharge MOS	Disconnect the load and contact support.
0123-0623	Heater Film Short Circuit	Heating circuit shorted	Power off immediately, stop using, and contact support.
0124-0624	Current Sensor Fault	Abnormal current measurement	Try restarting and observe if it recovers. If not, contact support.
1004	Inverter Short Circuit	Short circuit at inverter output	Power off immediately, remove the faulty load, then power on again. If still abnormal, contact support.
1007	Inverter Fuse Abnormal	Inverter-side fuse issue	Stop using the device and contact support promptly.
1008	Inverter Relay Abnormal	Inverter-side relay stuck or not actuating	Stop using the device and contact support promptly.
1013	Grid Short Circuit	Short circuit on the AC mains side	Disconnect the grid immediately and inspect. Contact an electrician/support.
1016	Grid Fuse Abnormal	AC mains-side fuse issue	Stop using the device and contact support promptly.
1017	Grid Relay Abnormal	Grid-tie relay stuck or not actuating	Stop using the device and contact support promptly.
1021	PV1 Reverse Polarity Protection	PV1 polarity reversed	Disconnect and reconnect PV1 with correct polarity.
1025	PV2 Reverse Polarity Protection	PV2 polarity reversed	Disconnect and reconnect PV2 with correct polarity.
1029	PV3 Reverse Polarity Protection	PV3 polarity reversed	Disconnect and reconnect PV3 with correct polarity.
1033	PV4 Reverse Polarity Protection	PV4 polarity reversed	Disconnect and reconnect PV4 with correct polarity.
1038	Heatsink Temp-Control Cable Unplugged	Temperature control cable not connected or came loose	Shut down and contact support to inspect and reconnect properly.
1041	Voltage Setting Error	Abnormal system voltage parameter settings	Stop using the device and contact support promptly.

Alarm Code	Fault Name	Cause	Solution Measures
1043	Internal Protection	System triggered an internal protection	Stop using the device and contact support promptly.
1044	Internal I/O Fault	I/O port abnormal or disconnected	Stop using the device and contact support promptly.
1046	Intake Fan Fault	Intake fan not spinning	Stop using the device and contact support promptly.
1049	Insulation Fault	Insulation resistance below safety threshold	Disconnect from the grid and power off immediately. Contact support/electrician.
1050	DC Output Overvoltage Protection	DC output voltage too high; protection activated	Try restarting and observe if it recovers. If not, contact support.

## 6.2 Warranty Exclusions

We do not accept any warranty claims for damages arising from the following reasons:

1. You cannot provide a valid purchase certificate.
2. Damage resulting from major natural disasters (e.g., earthquakes, tsunamis, typhoons, floods) or significant social events (e.g., war, riots, government intervention).
3. Damage caused by accidental incidents or improper usage.
4. Issues arising from incorrect installation, deployment, testing, configuration, or operation contrary to the instructions provided in the user manual.
5. Damage resulting from destroying the anti-tamper sticker or disassembling/modifying the product.
6. Products purchased from unauthorized distributors or retailers.
7. Products that have not been charged and discharged for more than six months will not be covered under warranty.

## 6.3 Routine Maintenance

### Maintenance Requirements

To ensure that the balcony energy storage system can operate stably for a long time, it is recommended that it be routinely maintained as described in this section.

Inspection contents	Inspection method	Maintenance interval
System cleaning	Clean the battery modules and PV panel surfaces regularly to remove dust or dirt.	Once every six months to once a year
Product appearance	<ul style="list-style-type: none"> <li>Observe whether there is any damage or deformation in the</li> </ul>	1 time every 6 months

	<p>product's appearance.</p> <ul style="list-style-type: none"><li>• Observe the product for abnormal noise during operation.</li><li>• Check whether the parameters of the product are set correctly when the system is running.</li></ul>	
Electrical connection	<ul style="list-style-type: none"><li>• Check whether the cable connection is detached or loose.</li><li>• Check the cables for damage.</li><li>• Check whether the interface terminals and waterproof cover are loose or detached.</li></ul>	Half a year after the first adjustment, and once every six months to one year thereafter.
Grounding reliability	Check whether the grounding cable is reliably grounded.	Half a year after the first adjustment, and once every six months to one year thereafter.

# 7 Emergency Handling

---

If an accident (including but not limited to the following) occurs on the site, ensure the safety of onsite personnel first and contact the Company's service engineers.

## Battery Falling or Strong Impact



If a battery is dropped or violently impacted during installation, it may become faulty and must not be used. Using a faulty battery will cause safety risks such as cell leakage and electric shock.

---

- If a battery has obvious damage or abnormal odor, smoke, or fire occurs, evacuate the personnel immediately, call emergency services, and contact the professionals. The professionals shall use fire extinguishing facilities to extinguish the fire under safety protection.
- If the appearance is not deformed or damaged, and there is no obvious abnormal odor, smoke, or fire, contact the professionals to transfer the battery to an open and safe place, or contact a recycling company for disposal.

## Flood

- Power off the system if it is safe to do so.
- If any part of the batteries is submerged in water, do not touch the batteries to avoid electric shock.
- Do not use batteries that have been soaked in water. Contact a battery recycling company for disposal.

## Smoke or Fire



- In case of smoke or fire, if there is a large amount of smoke in the battery storage room, do not open the door to prevent explosion risks and toxic gas inhalation.
- If a lithium battery catches fire, flammable and toxic gases will be released. Therefore, during the extinguishing process, all firefighters must wear a full set of protective suits, including flame retardant/fireproof clothing, air-purifying respirator or breathing apparatus, firefighter helmet and mask, and insulated shoes.
- A lithium battery fire may last for several hours. After it is extinguished, the fire may

be reignited by the heat generated from residual ingredients due to internal cell damage. After an open flame is extinguished, continue spraying water to cool the batteries. Wait until the battery temperature drops to room temperature $\pm 10^{\circ}\text{C}$  and monitor for 24 hours to ensure that there is no sign of temperature rise before removing the batteries. Move the removed batteries to a safe place (an open and safe outdoor place is recommended), and then place the batteries in the fire sandbox or salt water.

---

If an ESS emits smoke or catches fire, household members should not dispose of the ESS by themselves. Follow the processes in the flowchart below.

The detailed description is as follows:

- 1) If batteries emit smoke or catch fires, notify all household members to evacuate immediately.
- 2) After evacuating to a safe outdoor area (20 m away is recommended), call the fire department immediately. While waiting for the fire rescue, contact the installer and technical support.
- 3) Firefighters arrive at the site and extinguish the fire.
- 4) After the fire is extinguished, set up a warning sign to isolate the area and spray water to reduce the battery temperature to room temperature $\pm 10^{\circ}\text{C}$ . (You can use an infrared thermometer or thermal imager.)
- 5) Observe the batteries for 24 hours and ensure that there is no sign of temperature rise before removing the batteries. (Only professionals are allowed to remove the batteries.)
- 6) After removing the batteries, move them to a safe place (an open and safe outdoor place is recommended), and place them in the fire sandbox or salt water. These operations must be performed by professionals who must take insulation measures, such as wearing insulated gloves, insulated shoes, and personal protective equipment (PPE).
- 7) After the battery fire is extinguished, if there is no potential risk onsite, the battery must be handled and recycled by professionals in accordance with local laws and regulations.

## Battery Leakage



- The leaked electrolyte is a colorless viscous liquid that may evaporate rapidly and is flammable, turning into white salt residues. The electrolyte has a pungent smell and is corrosive, irritating to eyes and skin. Avoid contact with it.
  - When handling chemical leakage incidents, professional maintenance personnel and firefighters must wear necessary protective equipment such as air-purifying respirators and other PPE.
-

For household members, if battery leakage occurs, you are advised to follow the following steps:

- 1) Set the power button to OFF.
- 2) Indoor installation scenario: Indoor personnel should quickly evacuate, open the doors, windows, and ventilation devices of the room, and turn off indoor fire sources during the evacuation. Outdoor installation scenario: Notify outdoor personnel to stay away from the site and set up a warning sign to isolate the area.
- 3) After evacuating to a safe area, notify professional maintenance personnel or firefighters to handle the emergency.

Avoid contact with electrolytes or released gases. In the case of contact, take the following measures:

- Inhalation: Evacuate from contaminated areas, get fresh air immediately, and seek immediate medical attention.
- Eye contact: Immediately wash your eyes with water for at least 15 minutes, do not rub your eyes, and seek immediate medical attention.
- Skin contact: Wash the affected areas immediately with soap and water and seek immediate medical attention.
- Intake: Seek immediate medical attention.

### **Conclusion and Follow-Up Procedure**

- After a battery fire is extinguished and there is no potential risk onsite, professionals handle and recycle the batteries after wearing insulated gloves, insulated shoes, and other PPE in accordance with local laws and regulations. After an accident occurs, the manufacturer can identify the damage to the device and replace the device according to the corresponding procedure to restore the ESS.
- After a battery fire is extinguished, the fire-extinguishing water may pollute the surrounding soil and water source. In this case, notify the related environmental protection department for evaluation and handling.